

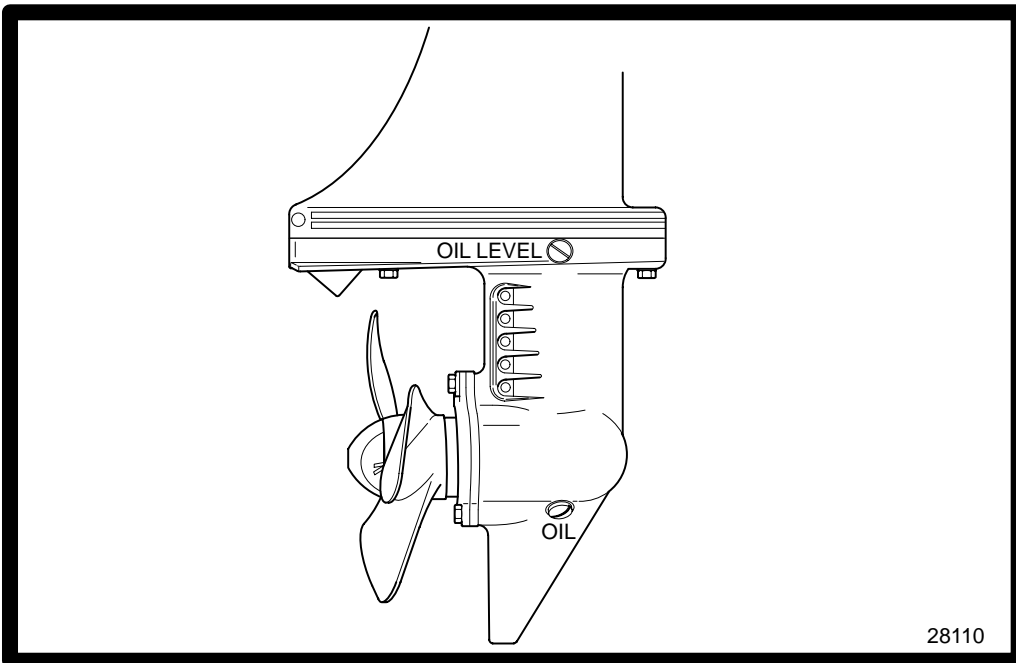

GEAR HOUSING (SHIFTABLE - F/N)



5

B



Table of Contents

	Page
Gear Housing	
(Shifttable - F/N)	5B-1
Specifications	5B-1
Special Tools	5B-1
Gear Housing Assembly Components	5B-2
Draining and Inspecting Gear Housing	5B-3
Propeller Removal	5B-3
Gear Housing Removal	5B-3
Gear Housing Disassembly	5B-4
Water Pump	5B-4
Bearing Carrier and Propeller Shaft	5B-6
Propeller Shaft Disassembly	5B-8
Driveshaft, Pinion Gear and Forward Gear	5B-8
Upper Driveshaft Bearing	5B-9
Lower Driveshaft Bearing/Forward Gear Bearing.	5B-10
Gear Housing Reassembly	5B-10
Propeller Shaft	5B-10
Installation of Lower Driveshaft Bearing	5B-11
Installation of Forward Gear Bearing	5B-11
Installation of Forward Gear	5B-11
Installation of Driveshaft	5B-12
Bearing Carrier Reassembly	5B-13
Shift Shaft Installation	5B-13
Forward Gear Backlash	5B-14
Propeller Shaft Installation	5B-14
Bearing Carrier Installation	5B-14
Water Pump Installation	5B-15
Gear Housing Installation	5B-16
Filling Gear Housing with Lubricant	5B-16
Gear Housing Installation	5B-16
Propeller Installation	5B-17



Gear Housing (Shiftable - F/N)

Specifications

Gear Ratio

Model 2.5/3.3 2.18:1

Gear Type Spiral Bevel

Clutch Type Sliding Dog

Propeller Drive System Drive (Shear) Pin

Lubricant Capacity 2.5 fl. oz. (74 ml)

Special Tools

Description	Part No.
Mandrel Kit	91-31229A5
Mandrel	37312
Mandrel	38628
Driver	91-37323
SNAP-ON TOOL	
Expanding Rod	CG-40-4
Collet 7/16	CG-40-9
Bearing Puller	91-27780
Slide Hammer	91-34569A1
Universal Puller Plate	91-37241





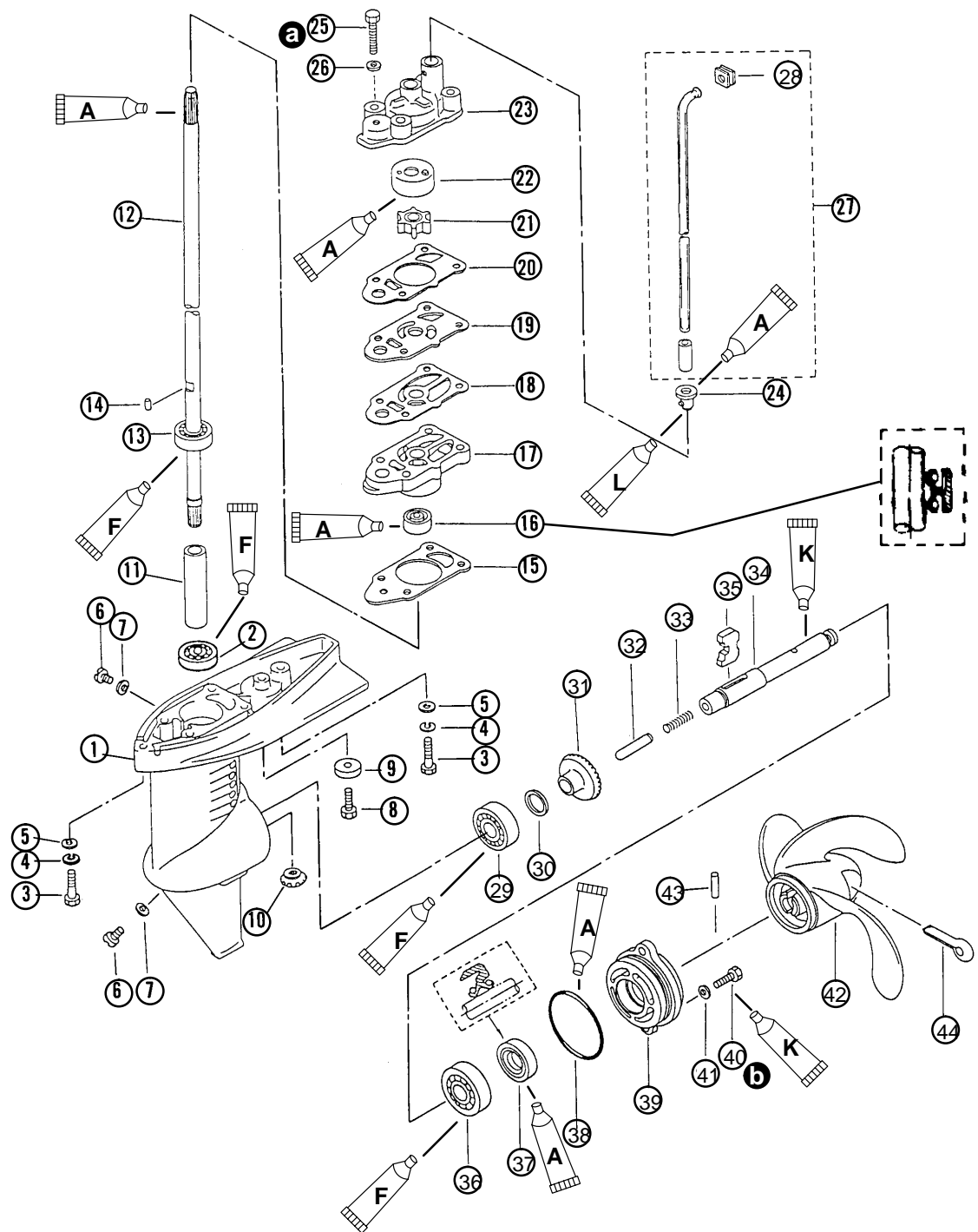

Gear Housing Assembly Components (Shiftable – Forward and Neutral)

- 1 - Housing
- 2 - Ball Bearing
- 3 - Bolt (2)
- 4 - Lock Washer (2)
- 5 - Washer
- 6 - Plug (2)
- 7 - Gasket (2)
- 8 - Bolt
- 9 - Anode
- 10 - Pinion Gear
- 11 - Spacer
- 12 - Drive Shaft
- 13 - Ball Bearing
- 14 - Impeller Key
- 15 - Gasket
- 16 - Seal
- 17 - Pump Base
- 18 - Gasket
- 19 - Guide Plate
- 20 - Gasket
- 21 - Impeller
- 22 - Insert
- 23 - Housing
- 24 - Grommet
- 25 - Bolt (4)
- 26 - Washer (4)
- 27 - Water Tube
- 28 - Grommet
- 29 - Ball Bearing
- 30 - Shim
- 31 - Gear
- 32 - Cam Follower
- 33 - Spring
- 34 - Propeller Shaft
- 35 - Clutch
- 36 - Ball Bearing
- 37 - Seal
- 38 - O-ring
- 39 - Housing
- 40 - Bolt (2)
- 41 - Washer (2)
- 42 - Propeller
- 43 - Shear Pin
- 44 - Cotter Pin



Quicksilver Lubrication/Sealant Application Points

-  2-4-C Marine Lubricant (92-90018A12)
-  Super Duty Gear Lubricant (92-13783A24)
-  Perfect Seal (92-34227A24)
-  Bellows Adhesive (92-86166)

Torque Specifications

- a** 70 lb. in. (7.9 N·m)
- b** 50 lb. in. (5.6 N·m)



Draining and Inspecting Gear Housing

⚠ WARNING

If gear housing is installed on outboard, disconnect (and isolate) spark plug lead from spark plug before working near the propeller.

1. With gear housing in normal running position, place a clean pan under housing and remove "OIL" fill screw with gasket and "OIL LEVEL" screw with gasket.
 - a. Inspect gear lubricant for metal particles (lubricant will have a "metal flake" appearance). Presence of metal flakes indicates the need for gear housing disassembly and component inspection.
 - b. Note color of gear lubricant. White or cream color indicates presence of water. Gear lubricant drained from a gearcase recently in operation will have a yellowish color due to lubricant agitation/aeration. This is normal and should not be confused with the presence of water.

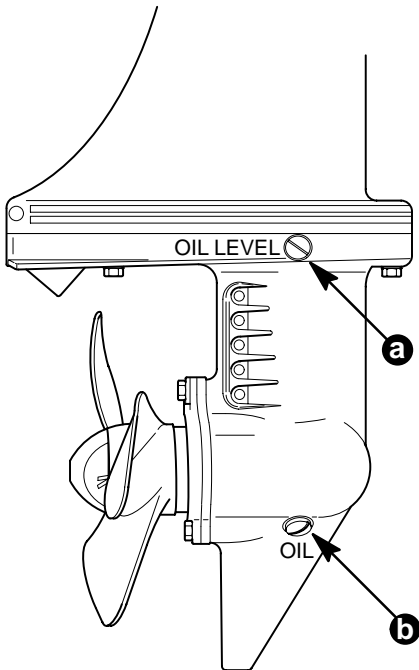

28110

- a - "OIL LEVEL" Screw with Gasket
- b - "OIL" Fill Screw with Gasket

Propeller Removal

⚠ WARNING

Before turning propeller or attempting to remove propeller, remove (and isolate) spark plug lead from spark plug to prevent engine from starting accidentally.

1. Remove cotter pin and pull propeller off from shaft.

2. Remove drive (shear) pin.

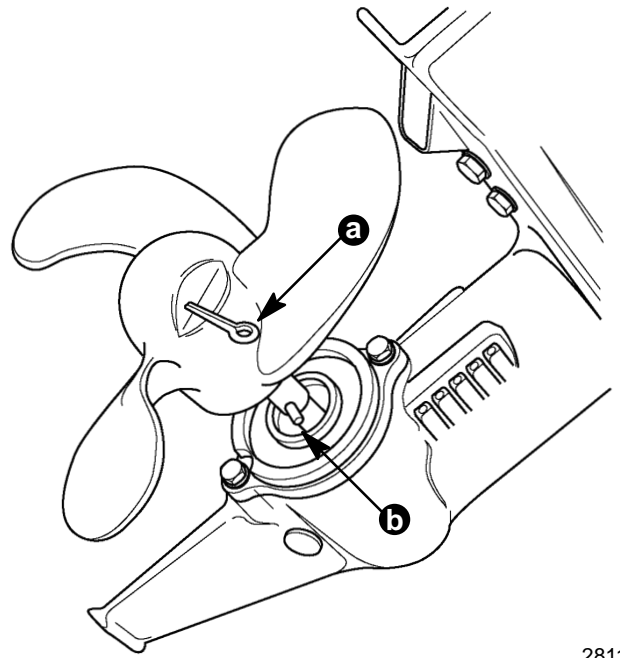

28111

- a - Cotter Pin
- b - Drive (Shear) Pin

Gear Housing Removal

1. Close fuel shut-off valve.

⚠ WARNING

To prevent accidental engine starting, remove (and isolate) spark plug lead from spark plug BEFORE removing gear housing from driveshaft housing.

2. Place gear shift lever in NEUTRAL position.
3. Tilt engine to full "UP" position.
4. Remove shift linkage access cover.

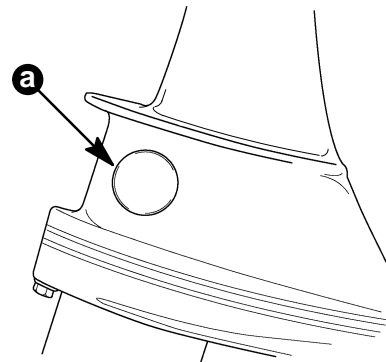

28112

- a - Cover



5. Loosen (DO NOT remove) linkage bolt.

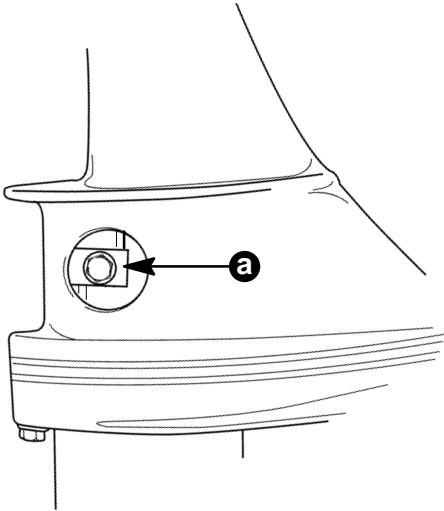

28113

a - Bolt

6. Remove 2 bolts (with flatwashers and lockwashers). Pull gear housing from driveshaft housing.

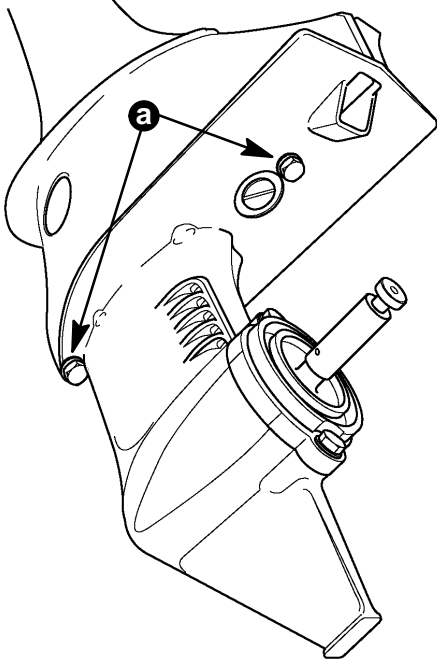

28114

a - Bolts

Gear Housing Disassembly

Water Pump

1. Remove 4 bolts (with flatwashers and lockwashers) securing water pump housing.

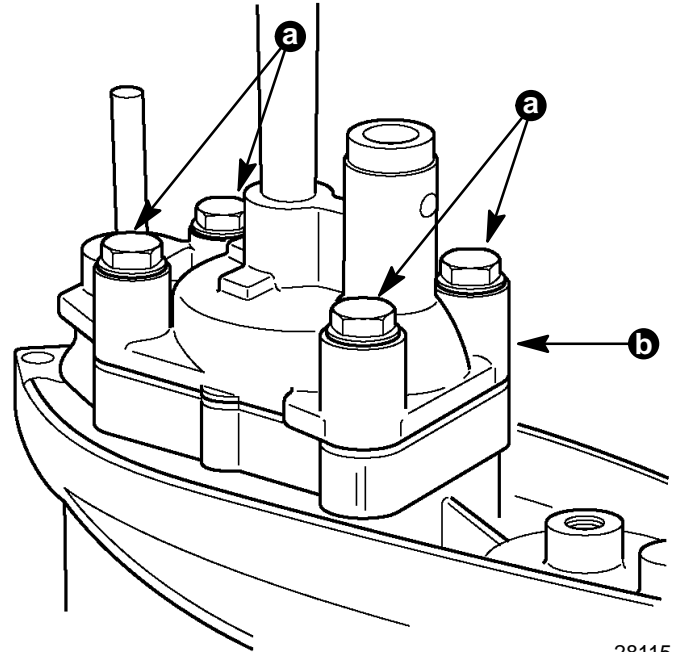

28115

a - Bolts
b - Housing

2. Use padding to protect gearcase surface while applying pressure against housing pry points.

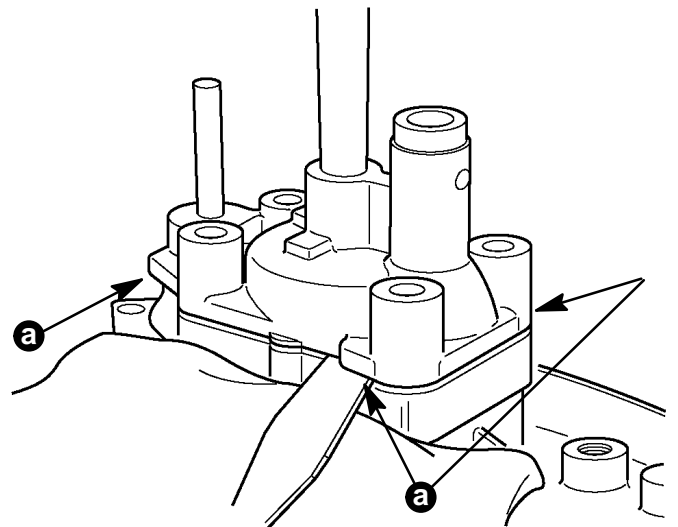

28116

a - Pry Points



3. Remove impeller and drive key from driveshaft. Replace impeller if:
 - a. Impeller blades are cracked, torn or worn.
 - b. Impeller is glazed or melted (caused by insufficient water supply).
 - c. Rubber portion of impeller is not bonded to impeller hub.

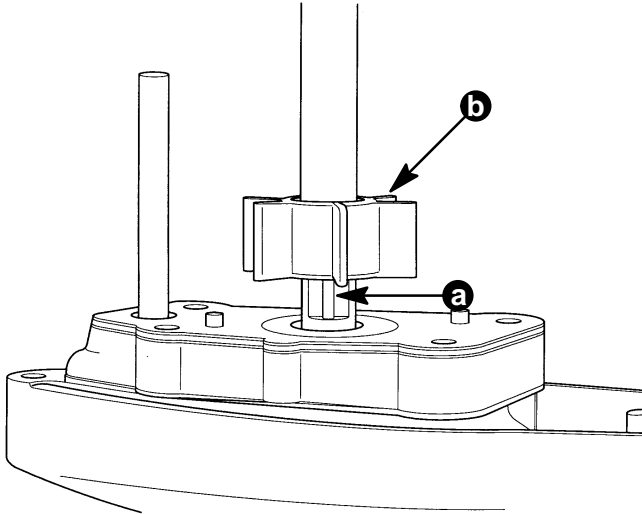

28117

- a - Impeller
- b - Drive Key

IMPORTANT: The circular groove formed by the impeller sealing bead should be disregarded when inspecting cover insert and base plate. The depth of the groove will not affect water pump output. If other grooves (from sand or debris) are present, insert and/or base plate should be replaced.

4. Remove plate and gasket.

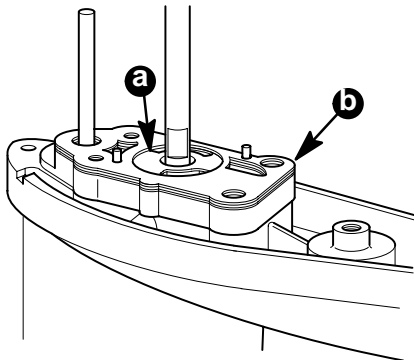

28118

- a - Base Plate
- b - Gasket

IMPORTANT: If water pump repair procedures ONLY are to be performed, hold driveshaft DOWN while prying/lifting up on pump base to prevent driveshaft from disconnecting from pinion gear. If driveshaft separates from pinion, gearcase must be disassembled to realign driveshaft with pinion gear.

5. Pad gearcase and pry up on pump base to remove base.

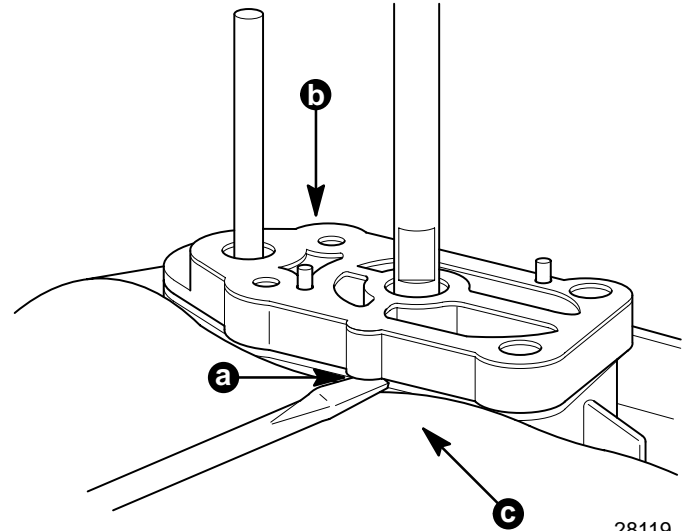

28119

- a - Pry Point
- b - Pump Base
- c - Pad



6. Shift shaft O-rings are located in both the upper pump housing and lower pump base. If sealing capabilities of O-rings are questionable, replace O-rings.

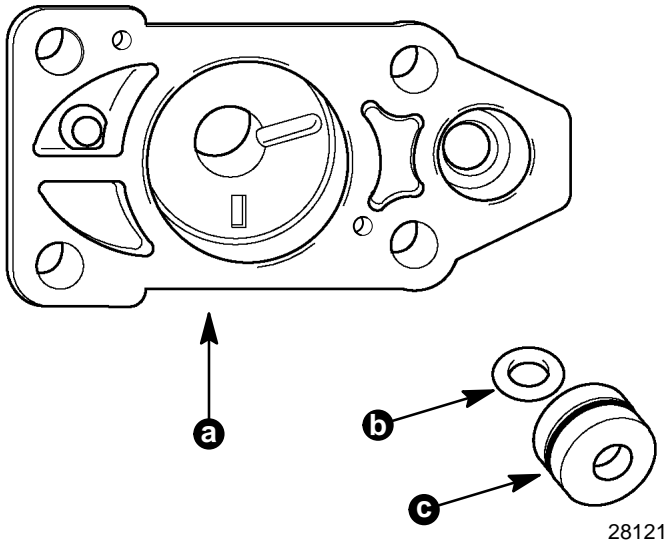

- a - Upper Housing
b - O-ring
c - Carrier O-ring

28121

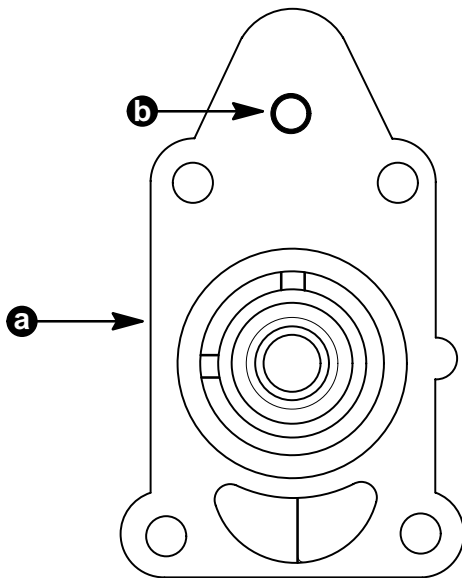

- a - Pump Base
b - O-ring

28122

7. If pump base seal is damaged, remove seal with a punch being careful not to damage base. Apply 2-4-C Marine Lubricant to cavity between new seal lips. Press new seal into pump base with a 11/16 or 16mm socket.

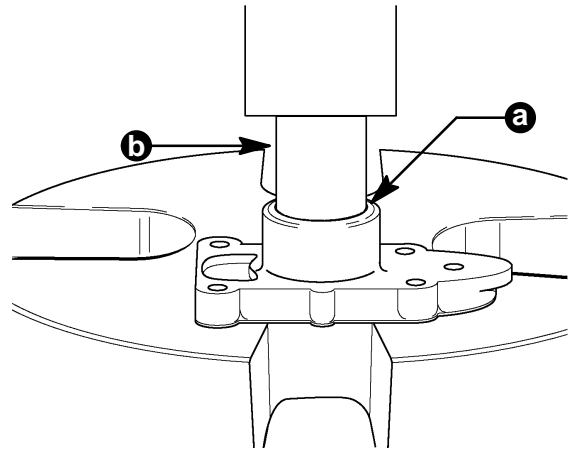

- a - Seal
b - Socket

28123

Bearing Carrier and Propeller Shaft

1. Drain lubricant; refer to "Draining and Inspecting Gear Lubricant".
2. Remove 2 bolts (with flat washers).

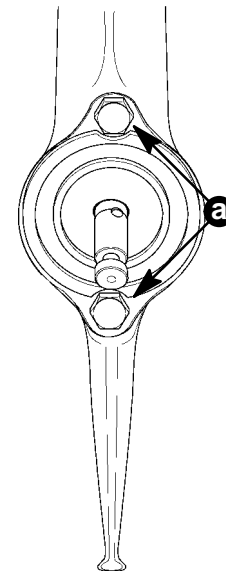

- a - Bolts

28124



3. Tap on either side of carrier with leather mallet to break adhesion between carrier and gearcase. Remove carrier and propeller shaft.

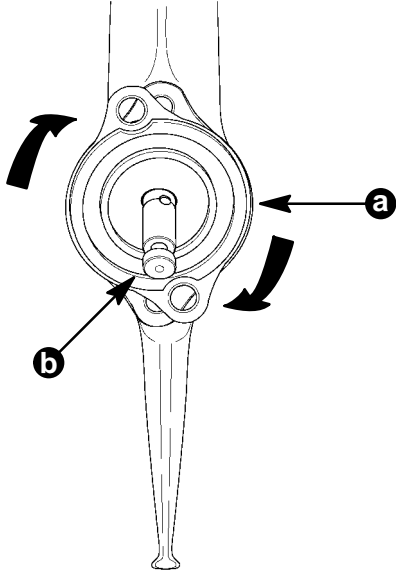

28125

- a - Carrier
- b - Propeller Shaft

4. Inspect carrier ball bearing for serviceability. If bearing is rusted or does not roll freely, replace bearing. If bearing must be replaced, use slide hammer (91-34569A1) with the following SNAP-ON TOOLS:

- a. Expanding Rod CG 40-4
- b. Collet 7/16 CG 40-9

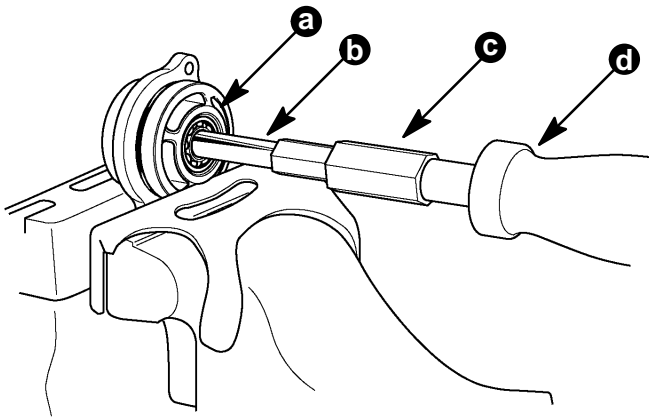

28126

- a - Bearing
- b - Collet (CG 41-13)
- c - Expanding Rod (CG 41-11)
- d - Slide Hammer (91-34569A1)

NOTE: Propeller shaft seal cannot be replaced without removing carrier bearing. Removal of bearing most likely will damage bearing. DO NOT remove bearing unless neces-

sary and at that time replace shaft seal also. Remove seal with screwdriver or punch.

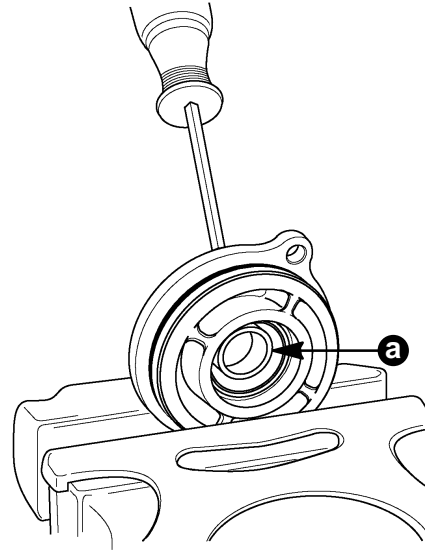

28127

- a - Seal

5. Remove carrier O-ring and inspect for cuts and abrasions.

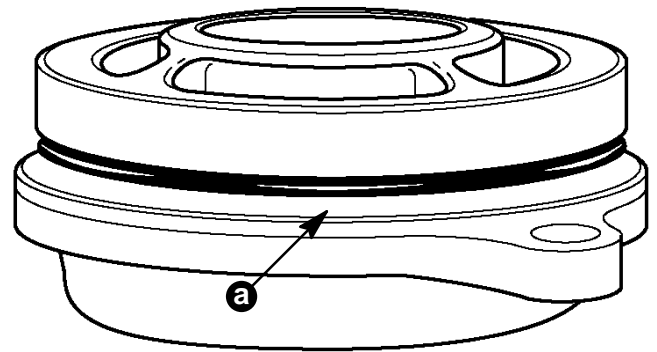

28128

- a - O-ring



Propeller Shaft Disassembly

1. Remove cam follower and inspect both ends for wear. If worn or pitted, replace follower.
2. Compress spring with awl or small screwdriver and remove clutch. Replace clutch if teeth are rounded or chipped or if wear is evident from cam follower or spring. Rounded jaws indicate the following:
 - a. Improper shift cable adjustment.
 - b. Engine idle speed too high while shifting.
 - c. Shifting too slowly.

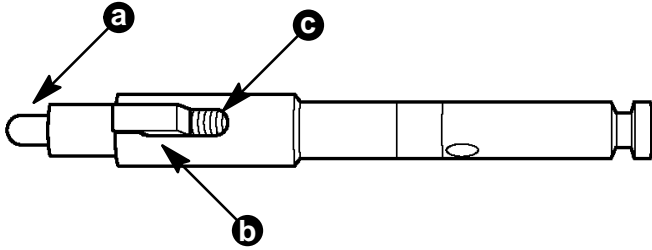

28129

- a - Cam Follower
- b - Clutch
- c - Spring

3. Replace propeller shaft if:
 - a. Oil seal surface is grooved.
 - b. Shaft has a noticeable "wobble" or is bent more than .006 in. (.152mm). Check with a dial indicator and V-block.

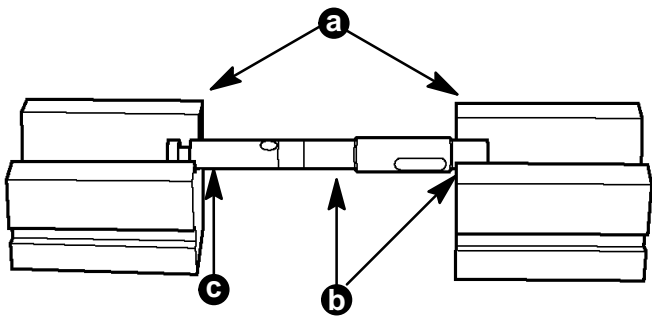

29130

- a - V-Blocks
- b - Bearing Surfaces
- c - Check with Dial Indicator Here

Driveshaft, Pinion Gear and Forward Gear

1. Remove driveshaft and sleeve from gear housing.

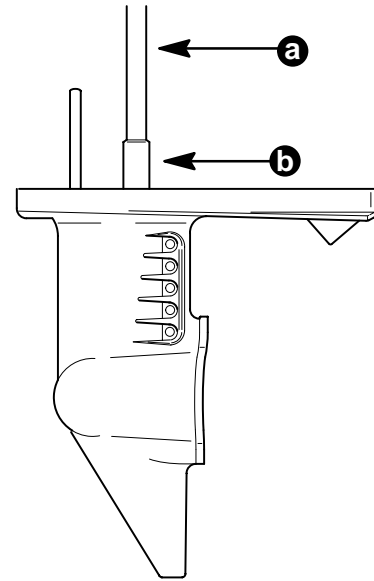

28131

- a - Driveshaft
- b - Sleeve

2. Remove base gasket and shift cam from gear housing.

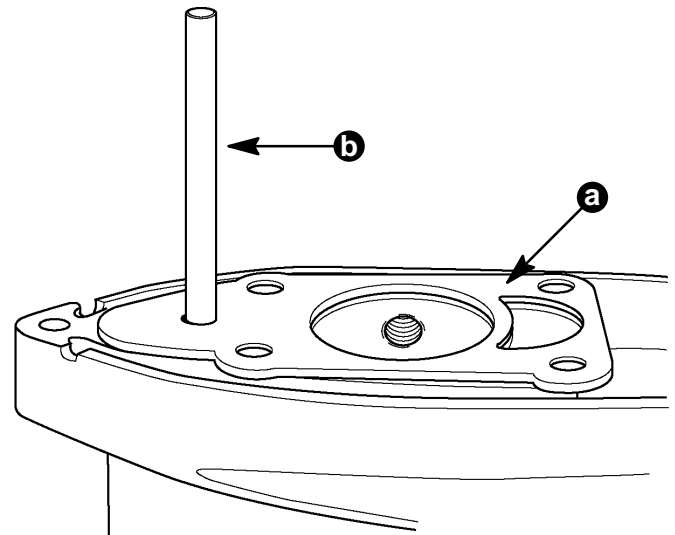

28132

- a - Gasket
- b - Shift Cam



3. Inspect shift cam face for roughness or gauling from cam follower. If cam face is worn, replace shift cam assembly.

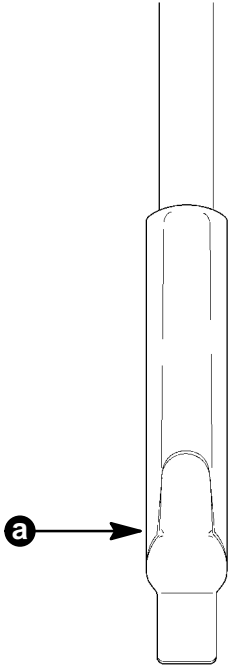

28133

a - Cam Face

4. Remove forward gear and shim.
 - a. Inspect forward gear clutch teeth for wear.
 - b. Inspect bronze bearing for wear.
 - c. Inspect forward gear and pinion gear for chips or excessive wear.

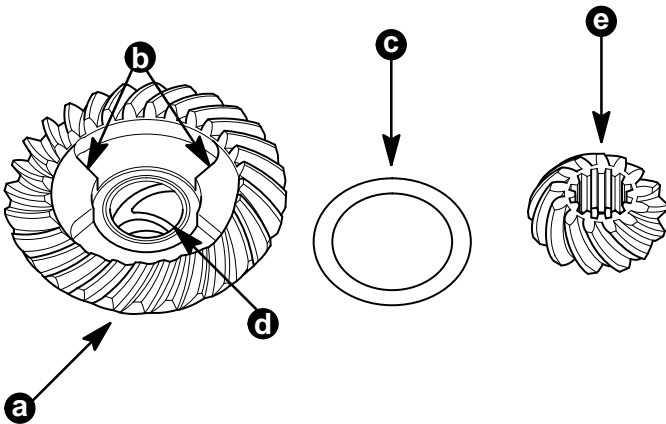

28134

a - Forward Gear
 b - Clutch Teeth
 c - Shim
 d - Bronze Bearing
 e - Pinion Gear

Upper Driveshaft Bearing

1. Inspect upper driveshaft ball bearing for rust or rough movement. If necessary, replace bearing. Use a Protector Cap (91-24161) to protect driveshaft while pressing bearing off while utilizing a Universal Puller Plate (91-37241).

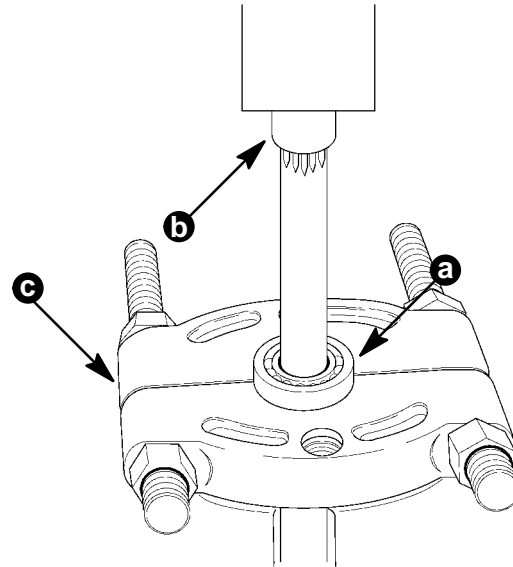

28135

a - Bearing
 b - Protector Cap (91-24161)
 c - Universal Puller Plate (91-37241)

2. Inspect driveshaft where water pump seals ride. If fingernail can catch in grooves, driveshaft should be replaced.

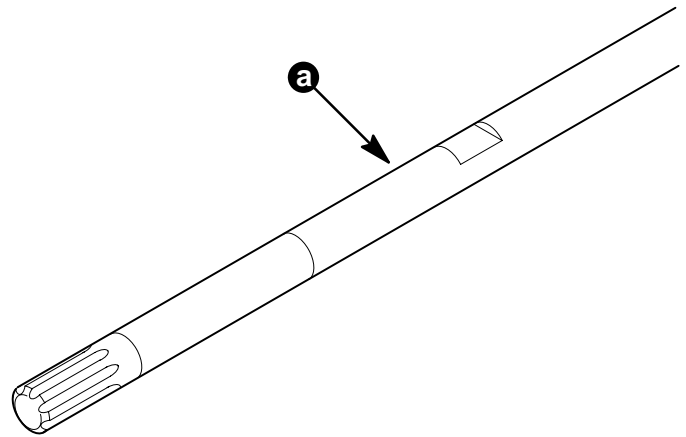

28136

a - Seal Surface



Lower Driveshaft Bearing/Forward Gear Bearing.

IMPORTANT: DO NOT remove FORWARD gear ball bearing or lower driveshaft ball bearing from gearcase unless replacement is necessary. Removal process may damage bearing.

IMPORTANT: If FORWARD gear bearing and lower driveshaft bearing are removed from gearcase, inspect gearcase for signs of bearing race spinning in their respective bores. This usually occurs as a result of bearing seizure from lack of lubricant or water intrusion. If such signs are apparent, gearcase must be replaced.

1. Inspect lower driveshaft ball bearing for roughness. If necessary, remove bearing by driving bearing downward with a 3/4 in. socket.

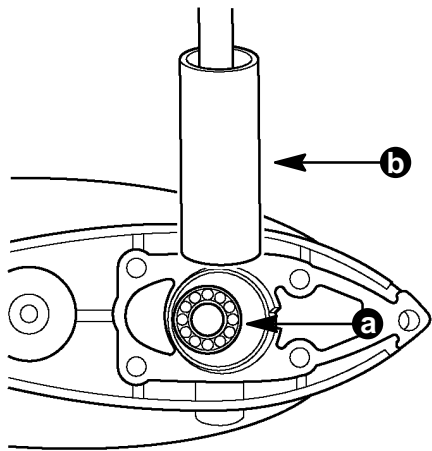

28137

- a - Bearing
- b - 3/4 in. Socket

2. Inspect FORWARD gear ball bearing for roughness. If necessary, remove bearing using Bearing Puller (91-27780).

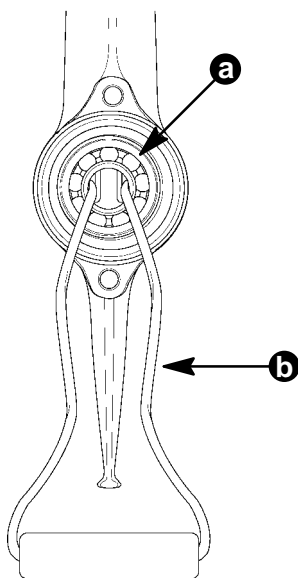

28138

- a - Bearing
- b - Bearing Puller (91-27780)

Gear Housing Reassembly

Propeller Shaft

1. Compress clutch spring and reinsert clutch into propeller shaft.
2. Apply a small amount of Quicksilver Needle Bearing Assembly Lubricant to the clutch end of cam follower. This will aid in retaining cam follower in propeller shaft during installation of shaft in gear housing.

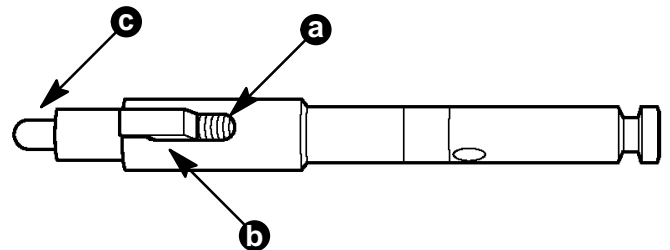

28139

- a - Clutch Spring
- b - Clutch
- c - Cam Follower



Installation of Lower Driveshaft Bearing

1. Lubricate O.D. of lower bearing race with Quicksilver Needle Bearing Assembly Lubricant. Place bearing into driveshaft bore (NUMBER SIDE UP). using a 3/4 in. socket, carefully tap bearing (CHECK ALIGNMENT FREQUENTLY) into position [approximately 1/8 in. (3.17 mm)] from bottom of bore.

IMPORTANT: If lower driveshaft bearing is not positioned low enough in driveshaft bore, water pump base will preload upper and lower driveshaft bearings resulting in premature failure of both bearings.

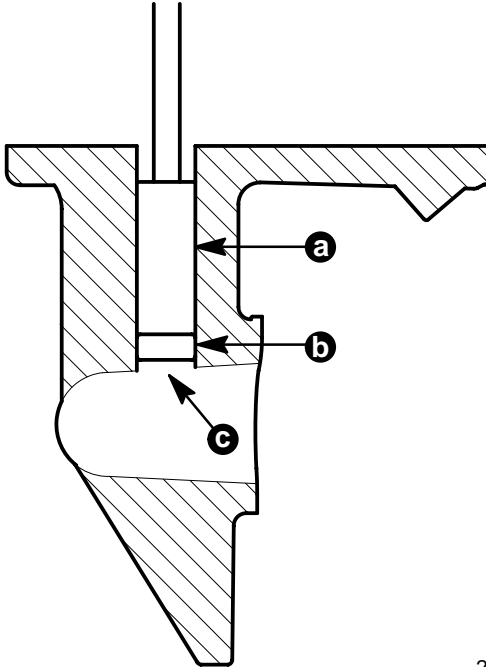

28140

- a - 3/4 in. Socket
- b - Bearing
- c - 1/8 in. (3.17mm)

Installation of Forward Gear Bearing

NOTE: Drive on NUMBER SIDE of bearing.

1. Lubricate O.D. of bearing with Quicksilver Needle Bearing Assembly Lubricant. Position bearing in gear case. Seat bearing in case using Mandrel (38628) and Driver (91-37323) from Mandrel Kit (91-31229A5).

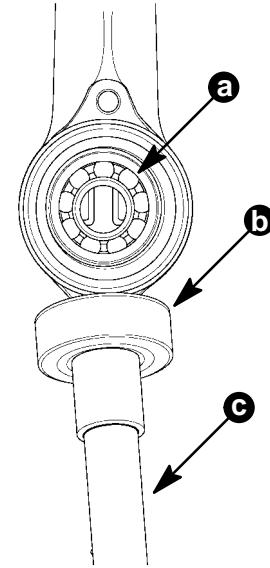

28141

- a - Bearing
- b - Mandrel (38628)
- c - Driver (91-37323)

Installation of Forward Gear

1. Lubricate forward gear bronze propeller shaft bearing and roller bearing surface with Quicksilver Gear Lubricant.
2. Place forward gear with shim (retained) into forward bearing.

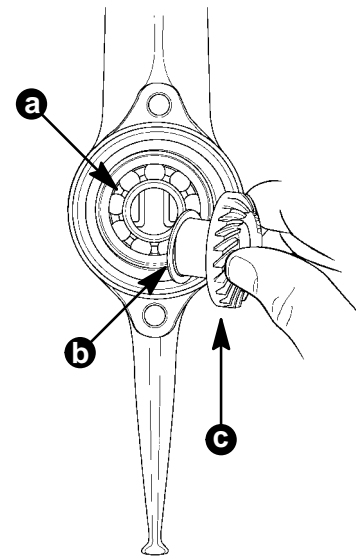

28142

- a - Forward Bearing
- b - Shim
- c - Forward Gear



Installation of Driveshaft

1. Lubricate I.D. of new upper driveshaft bearing with Quicksilver Needle Bearing Assembly Lubricant. In order to position bearing at the proper height on drive-shaft, fabricate a driver tool to the following dimensions:

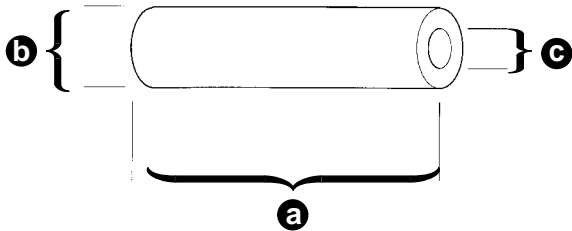

28143

- a - 3-5/8 in. (92.07mm)
- b - 3/4 in. (19.05mm)
- c - 13/32 in. (10.31mm)

2. Place driveshaft (crankshaft end) on a padded surface. Place bearing on pinion end of shaft and using fabricated driver tool, tap bearing down driveshaft until tool is flush with pinion end of shaft.

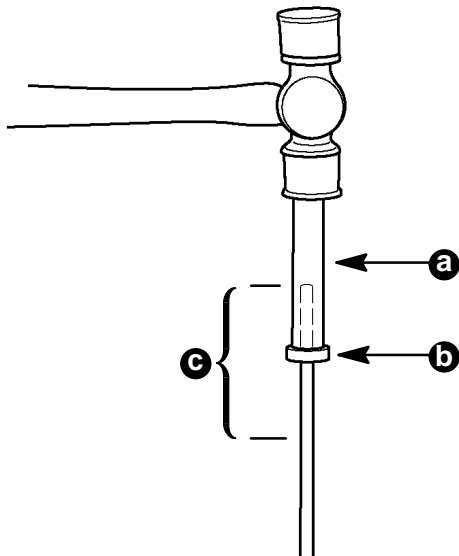

28144

- a - Tool
- b - Bearing
- c - 3-5/8 in. (92.07mm)

3. Place sleeve into housing.

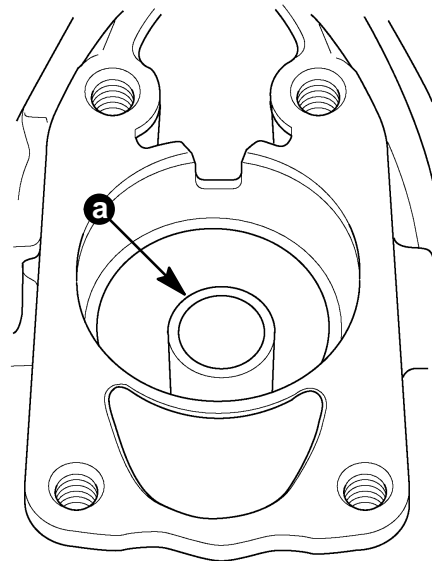

28145

a - Sleeve

4. Slide driveshaft assembly through sleeve into housing while installing Pinion gear onto lower driveshaft splines.

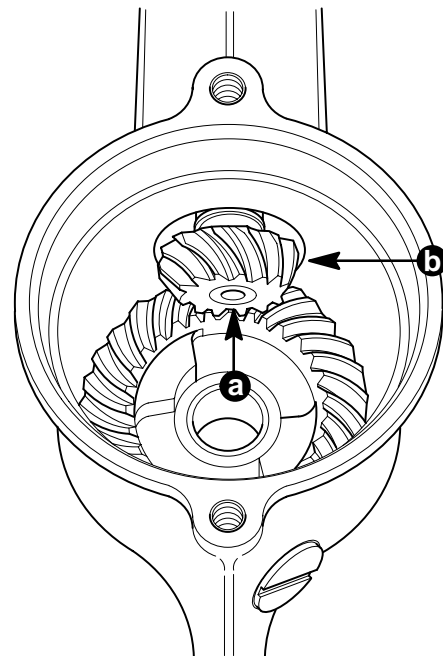

28146

a - Driveshaft
b - Pinion Gear



Bearing Carrier Reassembly

1. Apply 2-4-C Marine Lubricant into space between new seal lips. Press new seal (FLAT SIDE DOWN) into carrier with 13/16 in. socket.

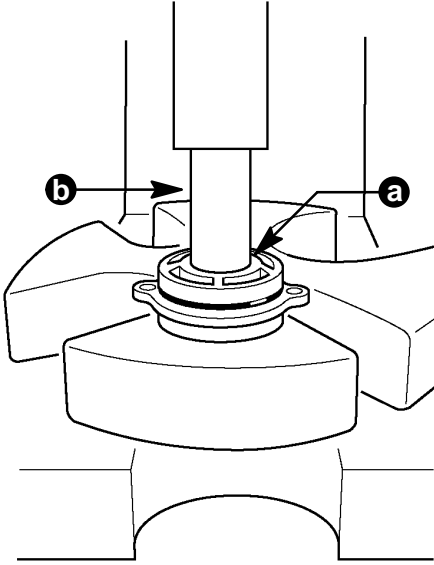

28147

- a - Seal (FLAT SIDE DOWN)
- b - 13/16 in. (Socket)

2. Apply Quicksilver Needle Bearing Assembly Lubricant to O. D. of new carrier bearing.
3. Press new ball bearing (NUMBER SIDE UP) into carrier until bearing seats using press or Driver (91-37323) and Mandrel (37312) from Mandrel Kit (91-31229A5).

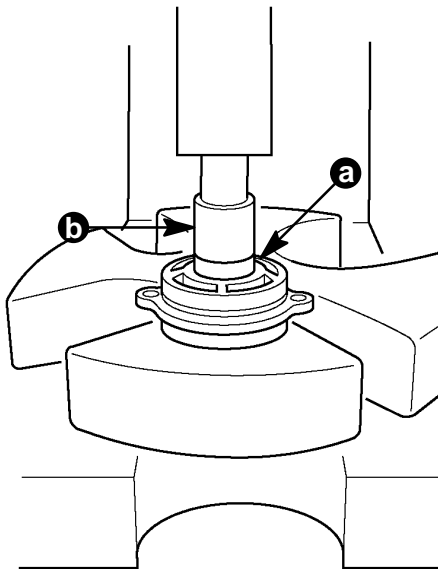

28148

- a - Bearing
- b - Mandrel (37312)

4. Install carrier O-ring. Apply 2-4-C Marine Lubricant to O-ring surface.

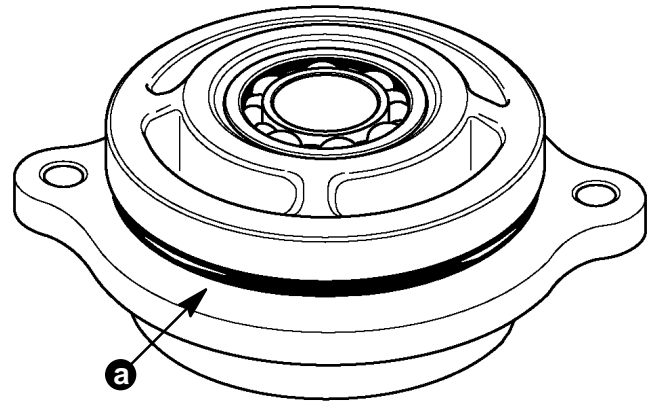

128149

- a - O-ring

Shift Shaft Installation

1. Install shift shaft in gear housing. Apply a light coat of 2-4-C Marine Lubricant to shaft to lubricate O-ring in pump base.
2. Install water pump base and new base gasket.

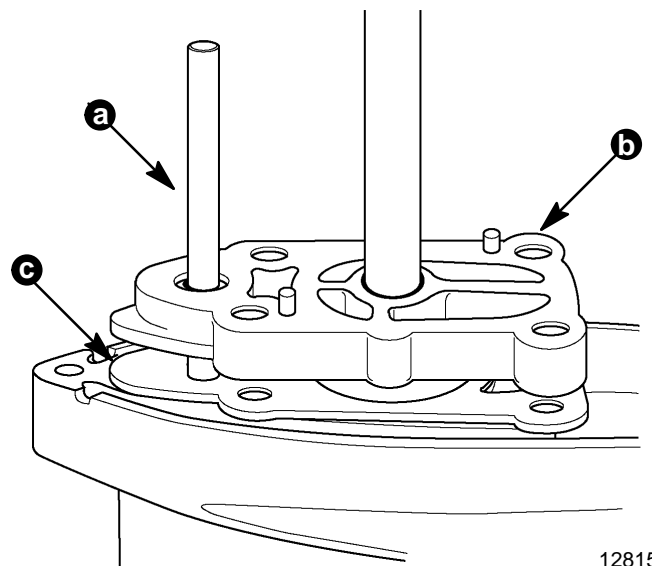

128150

- a - Shift Shaft
- b - Pump Base
- c - Base Gasket



Forward Gear Backlash

NOTE: The amount of backlash is not critical; NO BACKLASH IS CRITICAL.

Check Forward gear backlash as follows:

- a. Apply DOWN pressure on driveshaft.
- b. Push UP on Pinion gear (gear floats on driveshaft)
- c. Rock Forward gear back-and-forth.

A light clicking sound [approximately 0.002 in. to 0.006 in.(0.050mm to 0.152mm) freeplay] should be heard. If excessive freeplay exists [over .012 in. (0.30mm)], gear case components should be inspected for wear. If NO freeplay exists, either Forward gear or Forward gear bearing are not seated properly in gearcase or lower driveshaft bearing (above Pinion gear) is positioned TOO LOW in driveshaft housing.

Propeller Shaft Installation

NOTE: Verify shift cam is aligned properly in gearcase.

1. Install propeller shaft assembly into Forward gear/bearing.

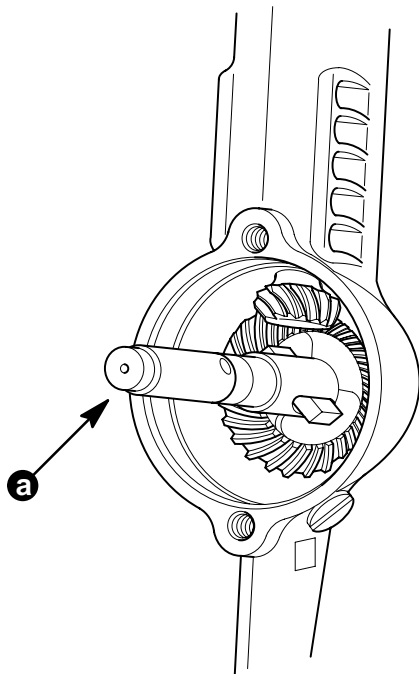

a - Propeller Shaft

28151

Bearing Carrier Installation

1. Slide bearing carrier assembly over propeller shaft. Secure carrier to gearcase with 2 bolts and flat washers. Torque bolts to 50 lb. in. (5.6 N·m).

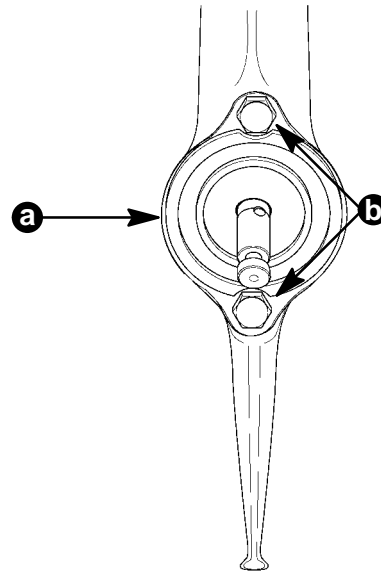

a - Carrier
b - Bolts with Washers [Torque to 50 lb. in. (5.6 N·m)]

28152

Water Pump Installation

1. Install new top base gasket, base plate (if required) and pump cover gasket.

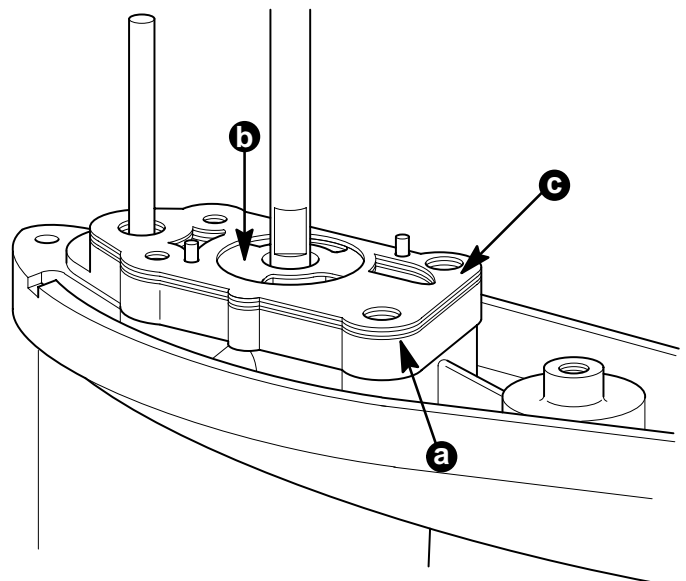

a - Base Gasket
b - Base Plate
c - Pump Cover Gasket

28153



2. Install drive key and impeller onto driveshaft. If reusing old impeller, DO NOT reverse impeller vanes or premature failure of vanes will occur.

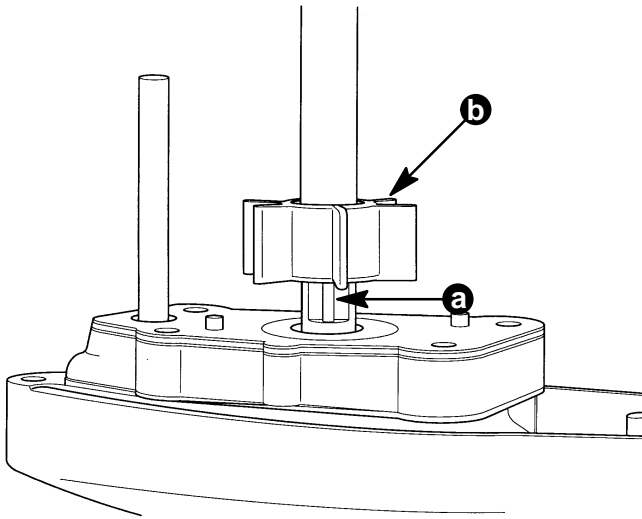

28154

- a - Drive Key
- b - Impeller

NOTE: Reapply a light coat of 2-4-C Marine Lubricant to shift shaft to lubricate O-ring in pump housing.

3. Apply a light coat of 2-4-C Marine Lubricant to inside of pump cover insert. Slide pump cover assembly down over driveshaft. Rotate driveshaft CLOCKWISE as pump cover is pressed down over impeller.

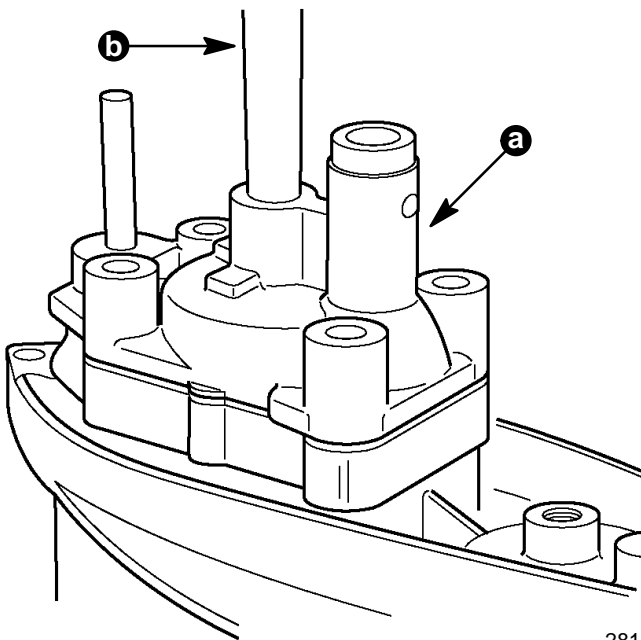

28155

- a - Pump Cover
- b - Driveshaft (Turn CLOCKWISE)

4. Secure pump cover to gearcase with 4 bolts, flatwashers and lockwashers. Torque bolts to 70 lb. in. (7.9 N-m).
5. Lubricate I. D. of water tube seal with a light coat of 2-4-C Marine Lubricant.

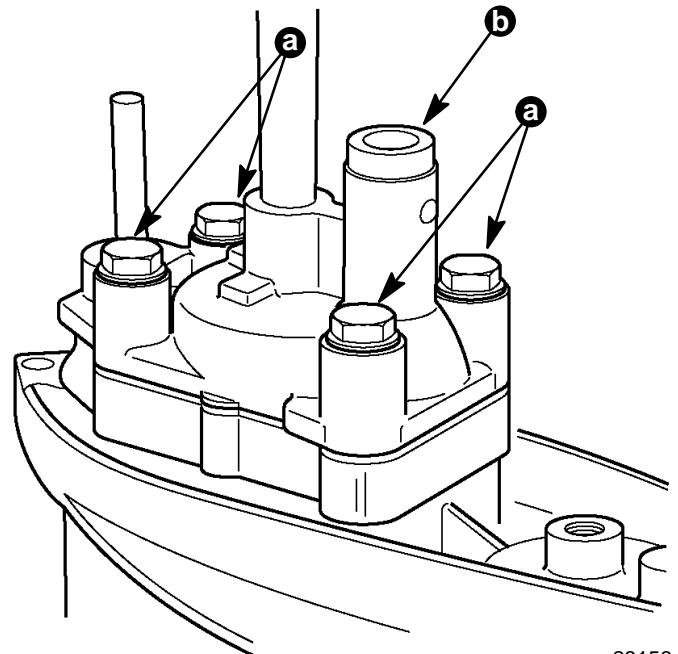

28156

- a - Bolts [Torque to 70 lb. in. (7.9 N-m)]
- b - Seal

Gear Housing Installation

Filling Gear Housing with Lubricant

NOTE: Gear housing lubricant capacity is approximately 2.5 fl. oz. (74ml).

⚠ WARNING

If gear housing is installed on outboard, disconnect (and isolate) spark plug lead from spark plug before working near propeller.

⚠ CAUTION

DO NOT use automotive grease in the gear housing. Use only Quicksilver Gear Lubricant.

1. Remove any gasket material from "OIL" fill and "OIL LEVEL" screws and gear housing. Install new gaskets on "OIL" and "OIL LEVEL" plugs.

IMPORTANT: DO NOT add lubricant without removing "OIL LEVEL" screw. Gear housing cannot be filled because of trapped air. Fill gear housing when driveshaft is in the vertical position.

2. Remove "OIL" fill screw and gasket.



3. Insert lubricant tube in "OIL" fill hole, then remove "OIL LEVEL" screw and gasket.

Gear Housing Installation

⚠ WARNING

Disconnect (and isolate) spark plug leads before installing gear housing onto driveshaft housing to prevent accidental starting.

1. Place shift lever in NEUTRAL position.
2. Tilt engine to full "UP" position.
3. Shift gear housing into NEUTRAL. Propeller will rotate freely in either position.

⚠ CAUTION

DO NOT lubricate top of driveshaft. Excess lubricant will not allow driveshaft to fully engage crankshaft. Tightening the gear housing fasteners (if excess lubricant is on top of driveshaft) will load the driveshaft/crankshaft and may damage either or both powerhead and gear housing. Verify top of driveshaft is free of lubricant.

4. Apply a light coat of 2-4-C Marine Lubricant to driveshaft splines.
5. Position driveshaft into driveshaft housing. Move gear housing upwards into driveshaft housing while aligning shift shaft, water tube and driveshaft splines.

NOTE: If driveshaft splines will not align with crankshaft splines, rotate flywheel slightly while pushing gear housing into driveshaft housing.

6. Secure gearcase to driveshaft housing with 2 bolts, flat washers and lockwashers. Torque bolts to 50 lb. in. (5.6 N·m).

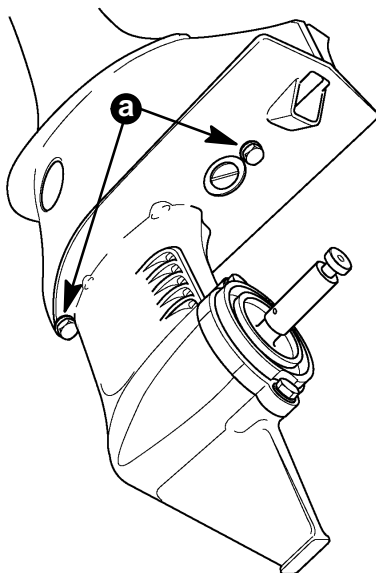

28157

a - Bolts (with flat washers and lockwashers) [Torque to 50 lb. in. (5.6 N·m)]

7. Tighten bolt clamping upper and lower shift shafts. With outboard in NEUTRAL, propeller shaft should turn freely. If propeller shaft DOES NOT turn freely in NEUTRAL, loosen clamping bolt and verify shift lever and gearcase are both in NEUTRAL. Retighten bolt. Reinstall access cover.

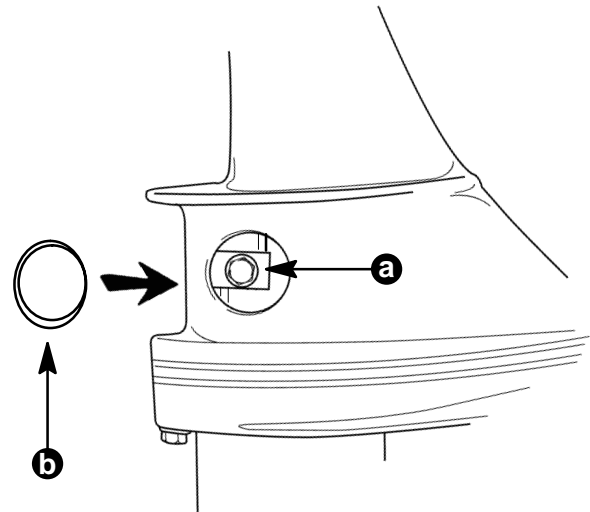

28158

a - Bolt
b - Access Cover

8. Verify correct shift operation. Propeller shaft should turn freely in either direction in NEUTRAL. In FORWARD, propeller shaft should turn approximately 90° in either direction before stopping. If shift operation is not as described, remove gearcase and inspect shift cam and clutch for proper assembly.
9. Inspect sacrificial anode on bottom of anti-ventilation plate for erosion. If 50% (or more) consumed, replace anode. DO NOT paint or apply a protective coating to the anode or corrosion protection will be lost.

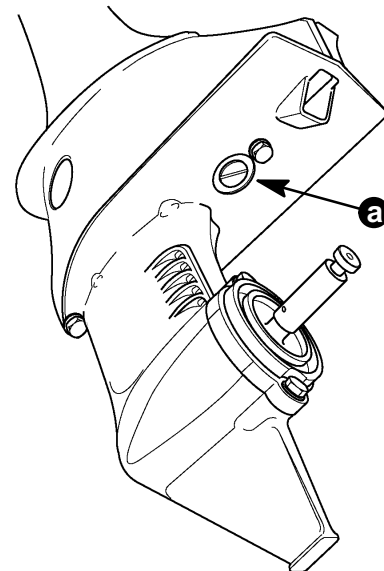

28159

a - Anode



Propeller Installation

⚠ WARNING

Disconnect and isolate spark plug lead when working near the propeller to prevent outboard from starting.

1. Insert shear pin into propeller shaft.
2. Slide propeller onto shaft and align with shear pin.
3. Secure propeller to shaft with new cotter pin.